

H U M A N S
S I N C E
1 9 8 2

Introduction

This manual will guide you through installing and operating the A million Times artwork, including setting the time and changing the choreography mode. We recommend that the manual is read in full prior to installation or removing the artwork from the crate. Please contact us at support@humanssince1982.com if you need any further assistance after reading the user manual or if you have any questions.

Please note:

- *Only place the A million Times artwork indoors. It is not intended for outdoor use.*
- *Do not expose the A million Times artwork to humidity as it can damage it.*
- *For repairs or maintenance please contact us at: support@humanssince1982.com.*

Contents

1	Crate Contents	
1.1	Main Crate	1
1.2	Accessory Box	2
2	Preparing for Installation of the Artwork	
2.1	Recommended Installation	3
2.2	Tools for Installation	3
2.3	Installation of the Hanging Cleat	4-5
3	Power, Connectivity and Cabling	
3.1	Power Requirements	6
3.2	Wall Preparation for hidden cabling	6
3.2	Hidden Cabling	7
3.3	Visible Cabling	8
4	Hanging the Artwork	
4.1	Power Test	9
4.2	Hanging the Artwork	10
5	Operation	
5.1	Power On the Artwork	11
5.2	Start the Artwork	12
5.3	Selecting Choreography and Time Mode	13
5.4	Set the Time	14
5.5	Stop the Artwork	15
5.6	Power off the Artwork	16
5.7	Calibration	17
6	Maintenance	
6.1	Prepare for Cleaning	18
6.2	Cleaning	18
7	Repairs	
7.1	Repairs	19
8	Warranty	
8.1	Repairs	20

Artwork Specification Sheet

Appendix

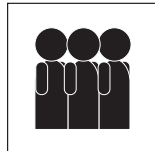

At least three people are required to hang the A million Times artwork.



The A million Times artwork is sensitive to impacts. Please handle with care.



Use the cotton gloves provided in the accessory box when handling the A million Times artwork. Don't handle the artwork without gloves as it can alter the artwork surface.



Before installing the A million Times artwork on the wall, make sure that your wall can support the weight specified in the artwork specification sheet at the end of this manual.

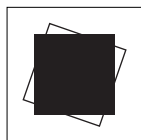

Place the A million Times artwork in a stable environment where no vibrations or shocks occur.

1 Crate Contents

1.1 Main Crate

The A million Times crate contains the A million Times artwork, hanging cleat, and accessory box.

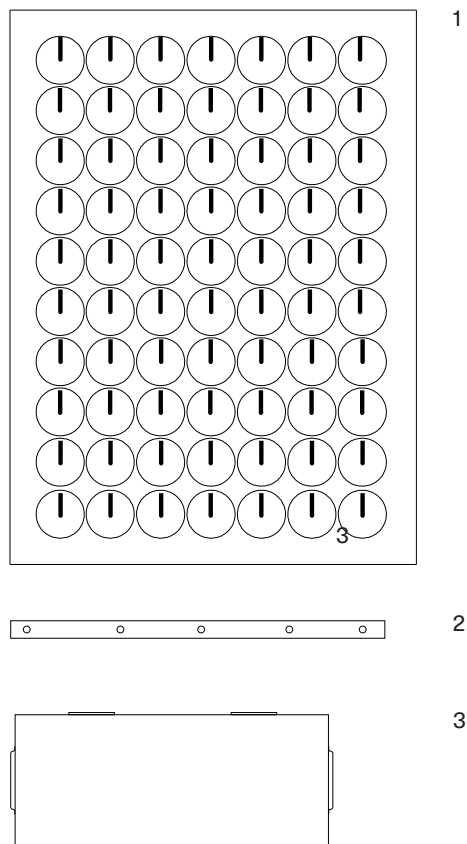

- 1. The A million Times artwork
- 2. Hanging cleat
- 3. Accessory box

1.2 Accessory Box

The accessory box contains the user manual, spare parts, electrical material and cleaning equipment . These items are stored over two tiers.

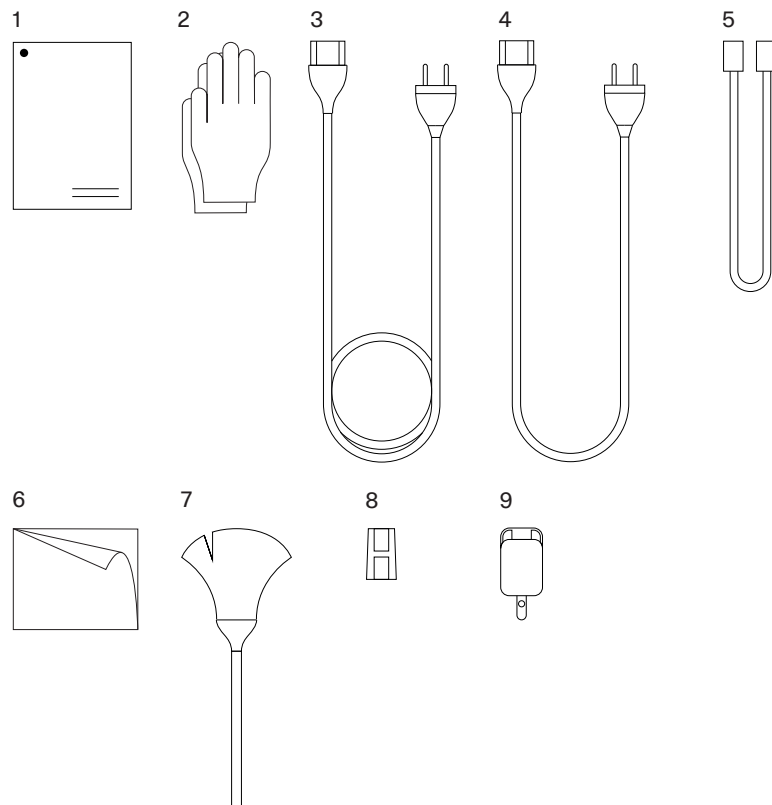

- | | |
|------------------------------|-----------------|
| 1. User manual & spec. sheet | 7. Duster |
| 2. Cotton & plastic gloves | 8. RJ45 coupler |
| 3. Power cable (L) | 9. Junction Box |
| 4. Power cable (S) | |
| 5. Ethernet cable | |
| 6. Cleaning cloth | |

Note:

If your artwork will require a UPS, you will receive addition dedicated materials

2 Preparing for Installation of the Artwork

2.1 Recommended Installation

We recommend that the artwork is installed, where possible, with the cable hidden. To install the artwork with hidden cables requires advance preparation of the installation site as outlined in Section 3.2 - 3.3. We also recommend, if possible, to install the artwork with a hidden Ethernet cable to enable the artwork to have an internet connection. The benefit of this is to offer remote technical support from the artists' studio in the event that any issues appear with either the artwork or the power supply. *More details are provided in Section 3. If you would like support from the studio to plan your installation please contact us: support@humanssince1982.com*

2.2 Tools for Installation

1. Anchors and screws for 6 mm holes
2. Drill
3. Tape measure
4. Spirit level
5. Pen

Note:

Please make sure to select anchors and screws that can support the weight of the A million Times artwork and are suitable for your wall material (see Artwork Specification Sheet).

2.3 Installation of
the Hanging Cleat

2.3.1 The hanging cleat is shipped inside the hanging slot of the A million Times artwork.

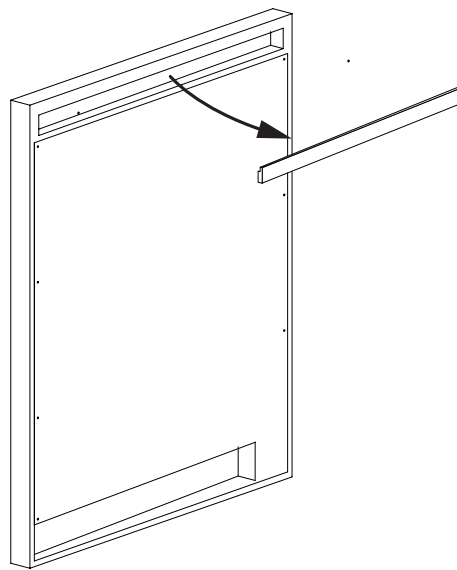

2.3 continued

2.3.2

To correctly place the hanging cleat, mark the drilling holes and position the hanging cleat using a spirit level for horizontality. Once installed the upper edge of the artwork will be 60 mm (2,3 inch) above the centre of the hole.

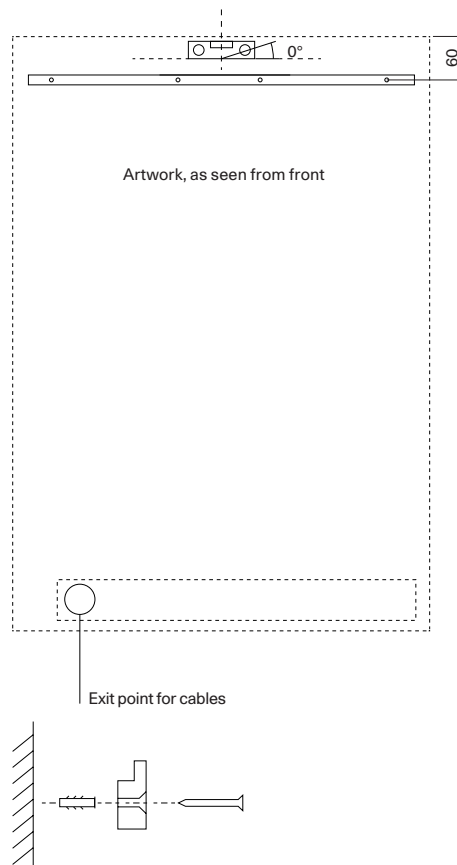

Note:

Please make sure to select anchors and screws that can support the weight of the A million Times artwork and are suitable for your wall material (see the Artwork Specification Sheet).

3 Power, Connectivity and Cabling

3.1 Power Requirements The A million Times artwork requires less than 1A at 230V AC to function.

3.2 Wall Preparation for Hidden Cabling Before installing the A million Times artwork, prepare the wall for a hidden cable installation. Hidden cabling is recommended to give the best visual appearance of the artwork. The recommended installation requires two cables to be hidden: the power cable and the Ethernet RJ45 cable for internet access that enable remote technical support from the artists' studio such as remote updates and maintenance. Use the general dimensions of the artwork in the *Artwork Specification Sheet* as a reference to determine the correct location of the exit hole for the cables.

Note:

In the event that the power cable cannot be hidden see section 3.4. In the event that an Ethernet cable cannot be installed please contact the studio to discuss suitable alternatives for providing remote technical support: support@humanssince1982.com

3.3 Hidden Cabling

Following the preparation of the wall for hidden cabling, to power the artwork, connect the Artwork Power Cable from the PSU (power supply) to the hidden wall outlet using the provided Power Cable (P). You can also connect the Artwork Power Cable to a hardwired outlet (H) using a junction box (J) with the supervision of a certified electrician. Connect the Ethernet RJ45 (W) cable to the port on the MC module. Store the junction box and the leftover cable in the pocket located in the back of the A million Times artwork.

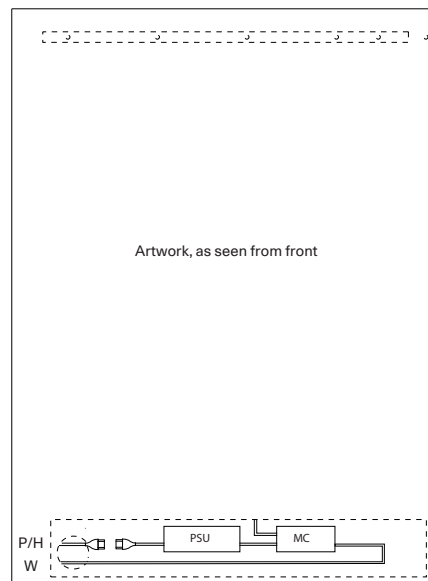
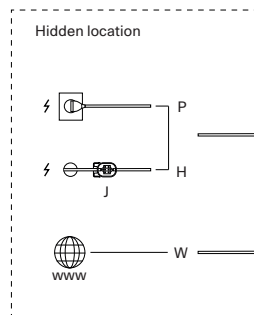

3.4 Visible Cabling

If it is not possible to accommodate a hidden cabling installation for the power cable, visible cabling is also possible. Connect the Artwork Power Cable from the PSU (power supply) to the wall outlet with the provided Power Cable (S). Store the leftover cable in the pocket located in the back of the A million Times artwork.

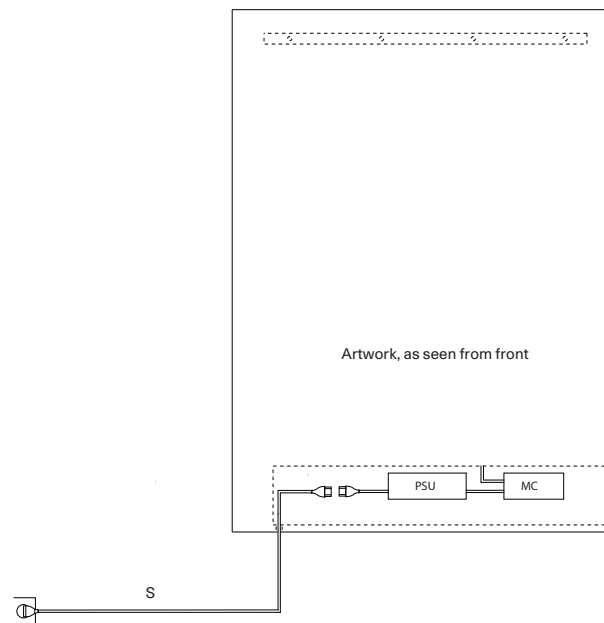

Note:

In case the installation location cannot accommodate a hidden Ethernet cable please contact us at support@humanssince1982.com to select appropriate alternatives for remote technical support.

4 Hanging the Artwork

4.1 Power Test

Prior to hanging, test the functioning of the artwork by connecting it to the power outlet. Remove the artwork from the crate and lean the artwork against a wall, keeping the protective foam around the edges. Connect the artwork to the power using the power cable in the Accessory Box and wait three minutes. The artworks clock hands will start to move, indicating a successful power test. If the power test succeeds, stop the artwork by pressing any of the three buttons for a minimum of 15 seconds until all clock hands move to “position 12:00” and unplug without turning off the power switch on the MC case and proceed with the installation.

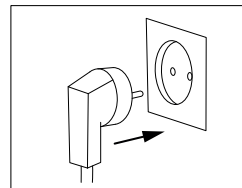
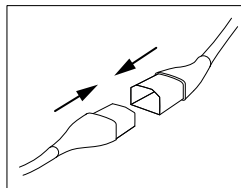
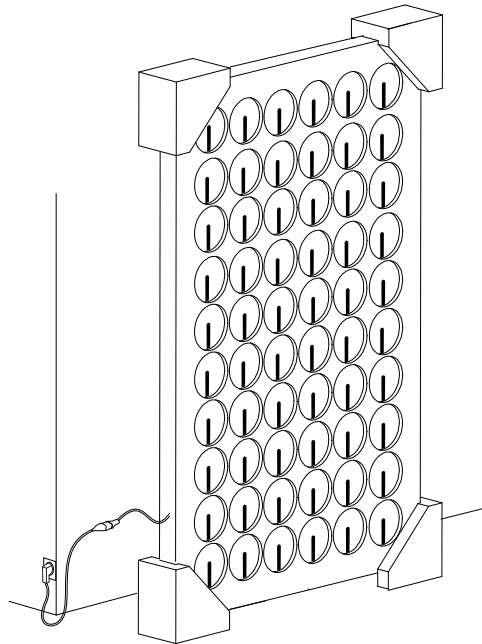

4.2 Hanging the Artwork

Make sure the power switch on the MC module is switched on before hanging. Carefully hook and centre the artwork onto the hanging cleat. At least three people are necessary for this operation. It is essential to lower the artwork in place on the hanging cleat slowly and gently.

To connect the cables:

1 - Pull the artwork away from the wall gently at the sides so that it slides forward on the hanging cleat creating a gap of 0,5 cm between the A million Times artwork and the wall.

2 - Gently pull the artwork away from the wall the bottom side. It will swing out from the hanging cleat allowing a gap at the bottom of around 5 cm to enable access to the electrical compartment to connect the power and Ethernet cables (as per 3.4 - 3.5). Please take care that the top of the artwork does not make contact with the wall during this process.

For some installation it may be possible and easier to connect the cables while the artwork is off the wall and then hang it.

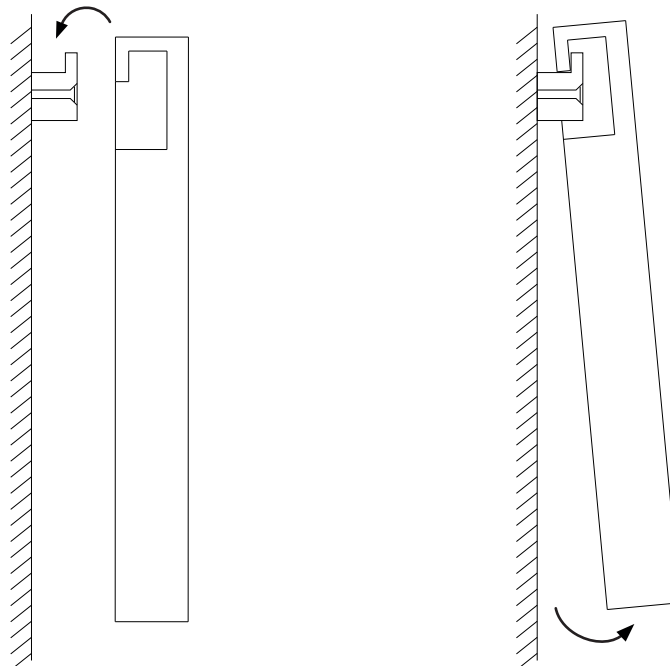

5 Operation

5.1 Power On the Artwork 5.1.1

Ensure you have connected the A million Times artwork to the power supply (see section 3).

5.1.2

To power on the artwork connect the artwork to the power outlet. If the power switch on the MC module is not turned on, do so now. The MC module is located in the electrical compartment at the back of the artwork. The hanging cleat is designed to allow you to access the electrical compartment and power switch without taking the artwork off the wall. Please do so gently and with care.

1 - Pull the artwork away from the wall gently at the sides so that it slides forward on the hanging cleat creating a gap of 0,5 cm between the A milltion Times artwork and the wall.

2 - Gently pull the artwork away from the wall the bottom side. It will swing out from the hanging cleat allowing a gap at the bottom of around 5 cm to enable access to the electrical compartment and turn on the power switch on the MC module. Please take care that the top of the artwork does not make contact with the wall during this process.

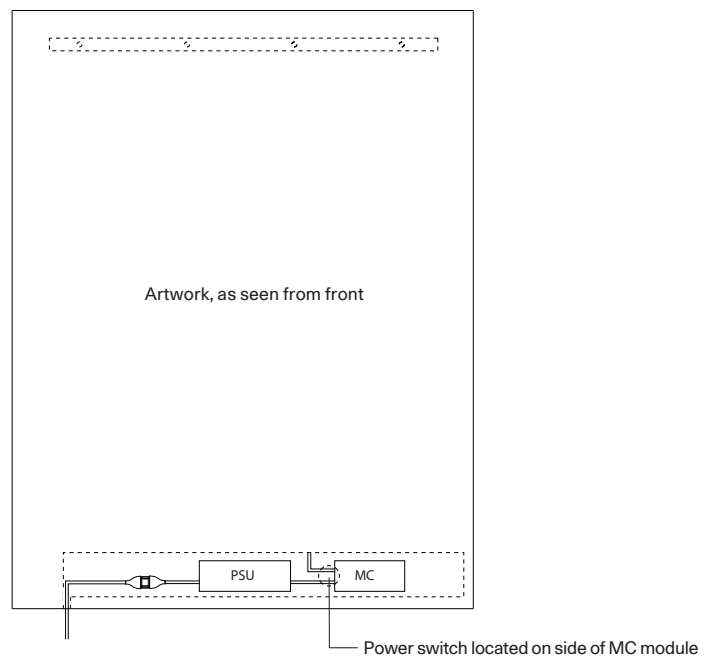

5.2 Start the Artwork

After power on, wait three minutes for the system to start, the artwork will automatically run a calibration process and then stop. To start the artwork push once any of the buttons on the bottom left underside of the artwork to start.

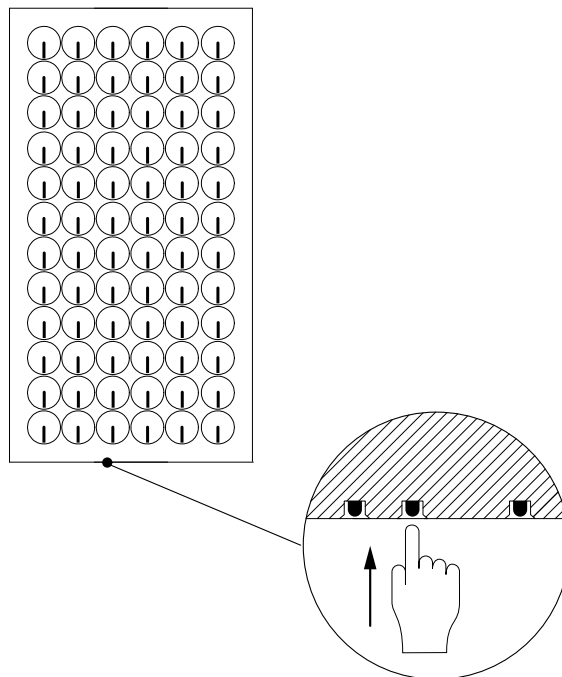
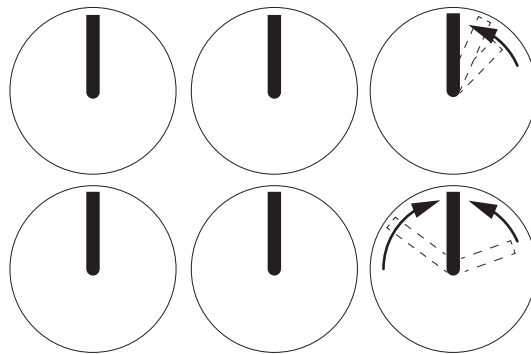

5.3 Selecting Choreography and Time Mode

The A million Times artwork comes with 3 choreography modes: Active(1), Original(2) and Minimal (3), all available in either 12 or 24 hour time displays. On the underneath left-hand side of the artworks there are three buttons. You can change the choreography mode by pressing the button on the right - the mode button. Press the mode button as many times as necessary until the desired mode is selected. Mode is displayed for 10 seconds before continuing with the choreographies.

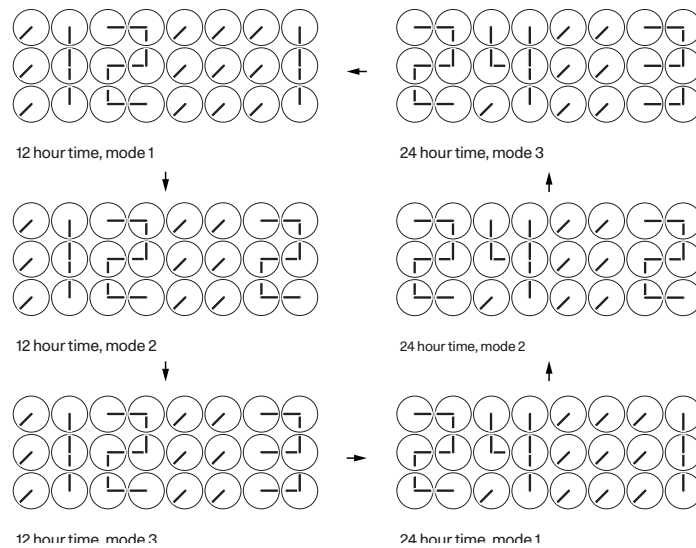

Mode 1: Active

This mode contains twenty different choreographies shown over twenty minutes on a loop. Every minute the clock hands perform one of the twenty choreographies before displaying the accurate time. This mode is the most varied.

Mode 2: Original

In this mode the clock hands perform the first original clock hand choreography developed by Humans since 1982 every minute before displaying the exact time.

Mode 3: Minimal

This mode displays only the time without any choreographies in between. Only the necessary clock hands will move to show the new time.

5.4 Set the Time

You can select the time by using the two buttons on the bottom left underside of the artwork. The furthest left button adds one hour per press. The second button from the left adds one minute per press. You can press the buttons as many times as necessary to set the desired time. After displaying the selected time for a short period the artwork will start showing the choreographies automatically and is now fully set up. In the case that you press the button too many times and go past the intended time, continue pressing the buttons to go back up through the numbers again.

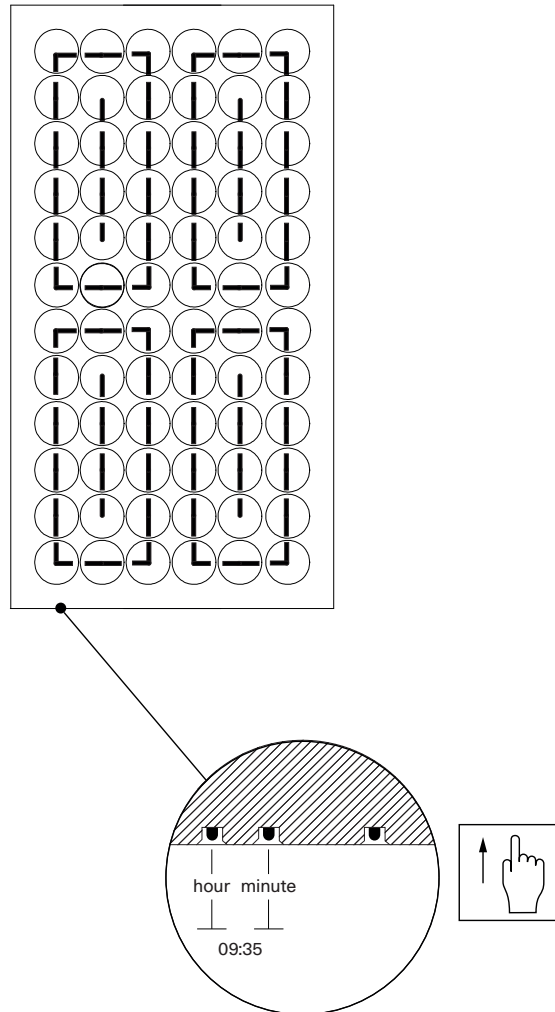

5.5 Stop the Artwork

The artwork should be stopped during cleaning or maintenance, and also prior to power off. To stop the artwork, press any of the three buttons for a minimum of 15 seconds until all clock hands move to “position 12:00” as below. The hands will remain in this position until it is started again. To re-start the artwork press any button and clock hands will return to position in the last selected mode.

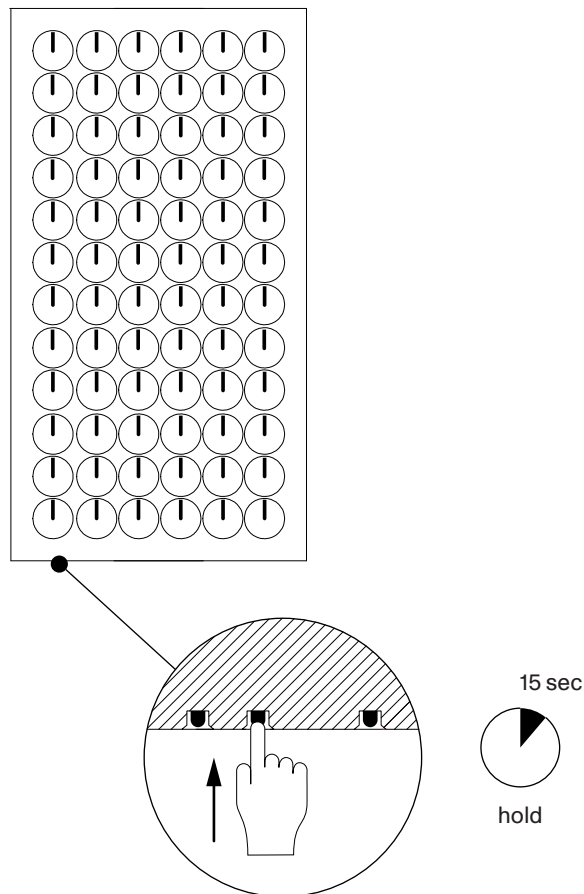

5.6 Power off
the Artwork

To power off the A million Times artwork first stop the artwork by pressing any of the buttons for a minimum of 15 seconds. Once all the hands are pointing up to 12:00, turn off the power switch located on the MC module at the back of the artwork. See section 5.1.2 for directions on accessing the MC module without removing the artwork from the wall.

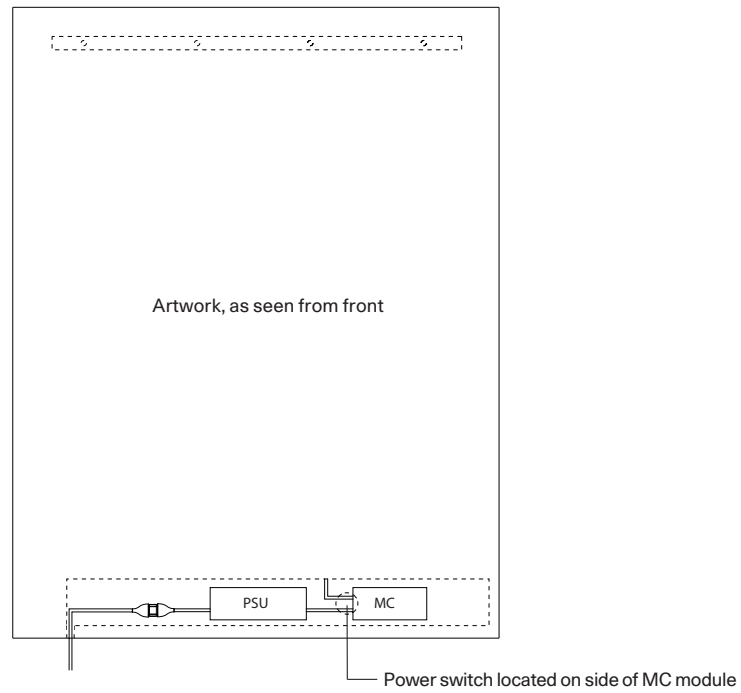

5.7 Calibration

The calibration process is automatically run when the artwork is powered on. If the hands look misaligned, the calibration process can be run any time by holding down all three buttons for minimum 30 seconds. Press any button to start the artwork after calibration.

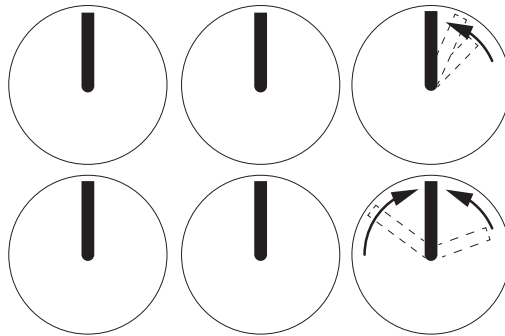

6 Maintenance

6.1 Prepare for Cleaning Before cleaning the A million Times you should stop the artwork. To stop the artwork press any of the three buttons for a minimum of 15 seconds, all the hands will point up to 12:00. The A million Times artwork will remain stopped until you press any of the three buttons once to restart. The clock hands will turn back into their initial position in the last selected mode.

6.2 Cleaning Once the artwork is turned off, you can clean the surface of the A million Times artwork with a cloth lightly damped in warm water. Avoid using window cleaners as they can leave a waxy build-up that dulls the surface. You can use the provided feather duster or a can of compressed air to remove the dust from the surface. If some hands were misaligned during the cleaning, you can run the calibration process described in chapter 5.7.

Note: The A million Times artwork should be cleaned at least once every six months to avoid dust related build-up and issues in the electronics which may affect the warranty.

7 Repairs

7.1 Repairs

Any repair work should only be carried out by Humans since 1982 support service or an expert authorised by Humans since 1982.

Do not attempt to repair or open the A million Times artwork yourself, doing so will invalidate the warranty.

If the A million Times artwork is damaged or not functioning properly, please contact us at: support@humanssince1982.com

8 Warranty

8.1 Warranty Terms

1. The Artist warrants the functioning of the mechanical and electrical components of the Art Piece for a period of three (3) years from the date of shipment for A million Times artworks. For ClockClock L Artworks the Warranty is two (2) years.

For Made-to-Order artworks, If the Buyer requests that the Artist stores the Art Piece for a period longer than 1 month at the Artists studio prior to shipment, the warranty period instead starts from the completion date of the Art Piece.

2. If any issue occurs with the Art Piece, the Artist will cover all costs for repairs during the Warranty Period.

3. For handling support cases, the Artist will primarily provide support remotely through phone or email. For more involved repairs the Artists may send a local support partner to the client's location, or an in-house support specialist representing the Artist will travel from Sweden to the client's location. In some rare cases, the artwork may need to be taken off-site to a support partner or returned to the artist's studio for further work if the Artist concludes this is needed to repair the Art Piece

4. The warranty is invalid if any malfunction should occur due to the Buyer's negligent acts or omissions, or in case the installation and/or relocation of the Art Piece is performed by an installer not recommended or instructed by the Artist. All art handlers or other qualified installers that handle the Artwork should be approved and briefed in advance by Humans since 1982.

5. After the Warranty Period is over, the Artist will still provide support and spare parts for the Art Piece as long as the Artist maintains its business. This service will be chargeable to the Buyer.

6. The Buyer is aware that the Art Piece is sensitive to humidity and heat, thus, the warranty is not valid if the Buyer should place or install the Artwork in humid environments or close to heat. The parameters for the safe installation of the artwork are at an Ambient temperature: +15 °C to +30 °C (+59°F to +86°F) with a Maximum Relative humidity: 80%